

**重要! 請詳細閱讀並  
保留以備參照!**

使用產品前請仔細閱讀說明書，  
並妥善保存說明書以便日後參考。

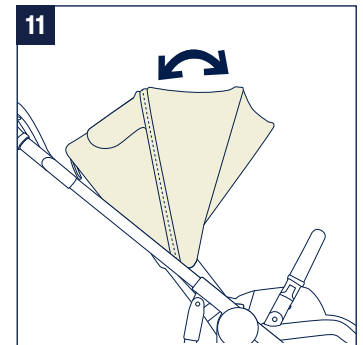

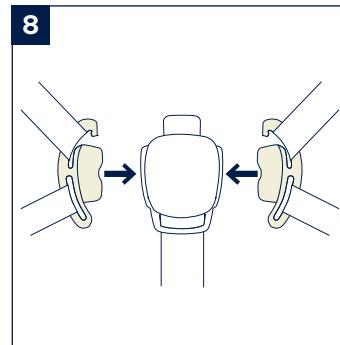

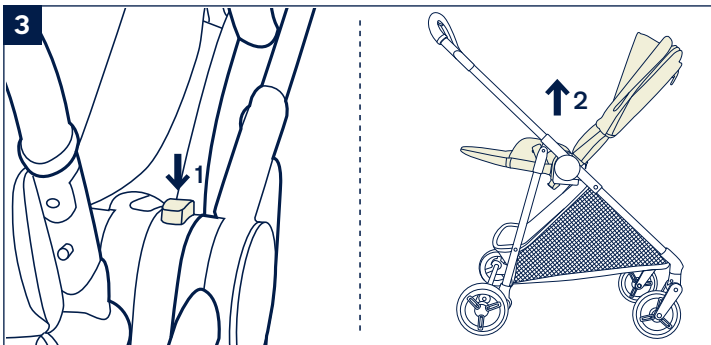
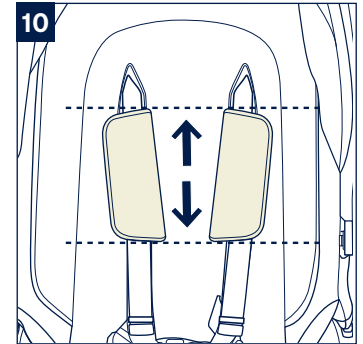
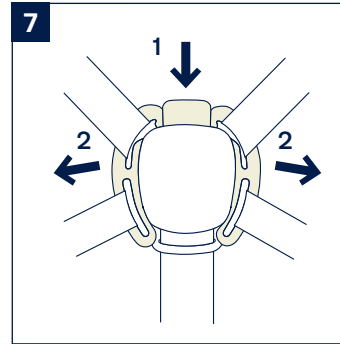
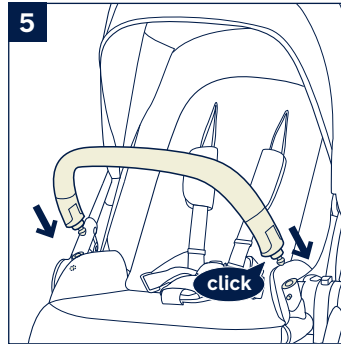
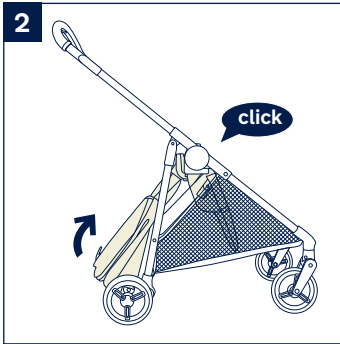
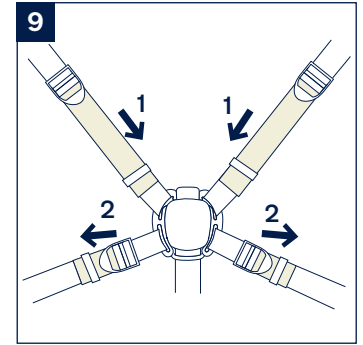
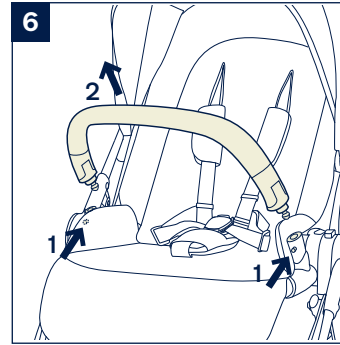
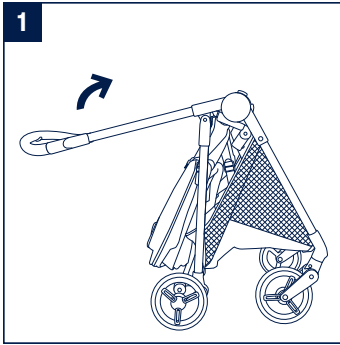
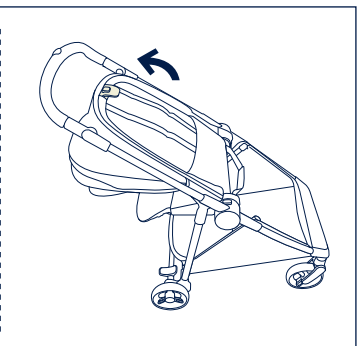
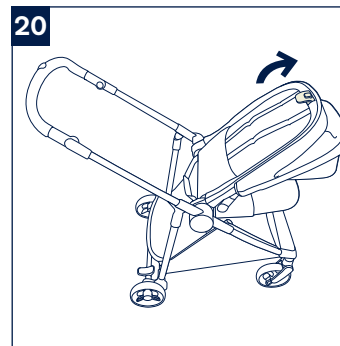
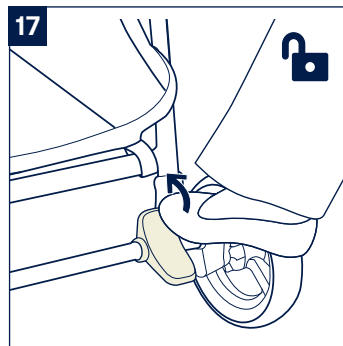
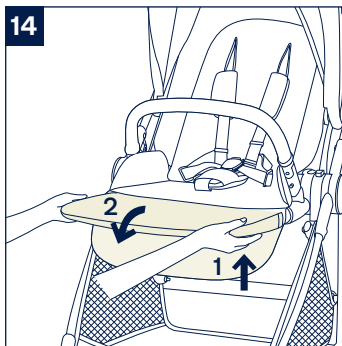
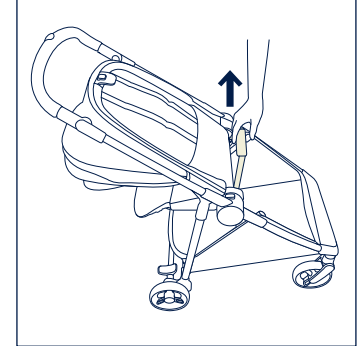
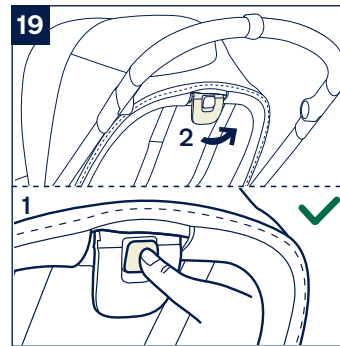
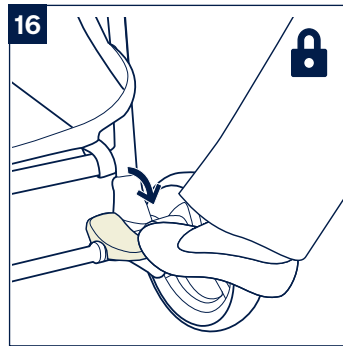
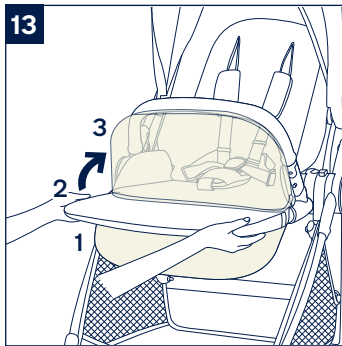
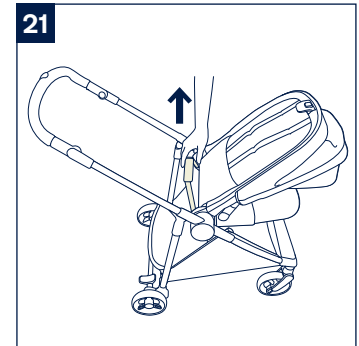
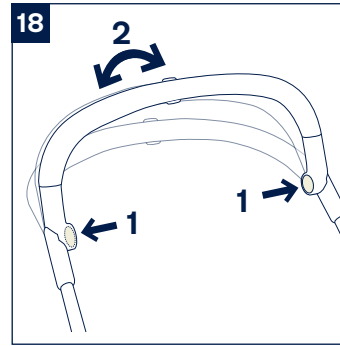
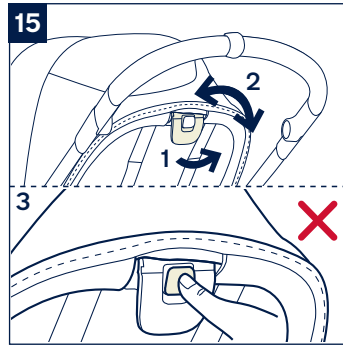
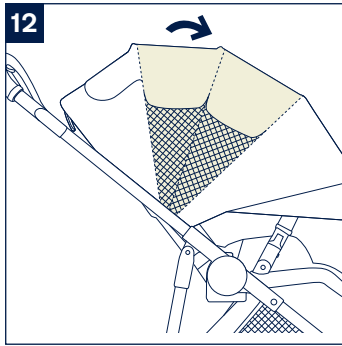
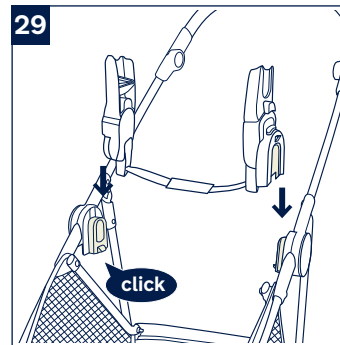
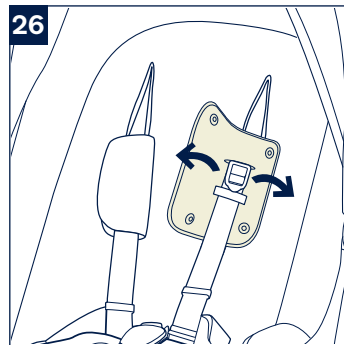
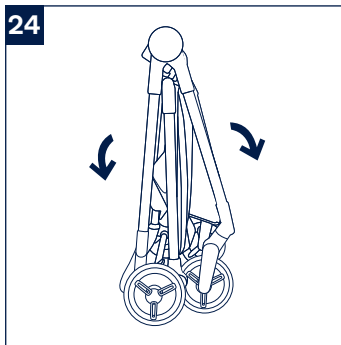
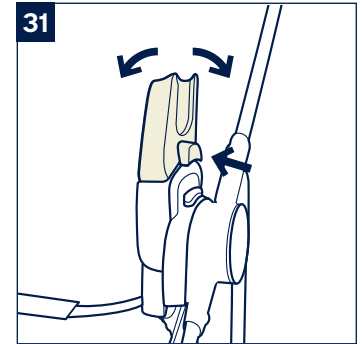
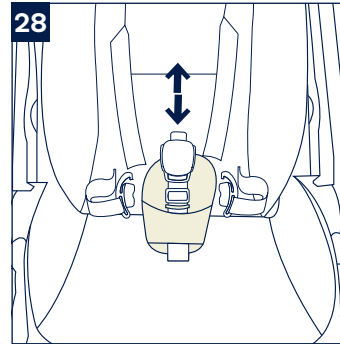
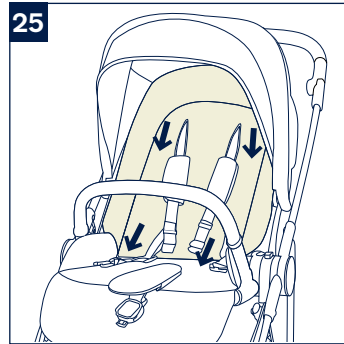
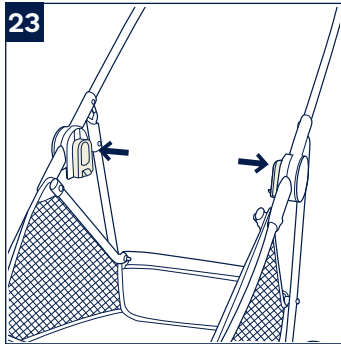
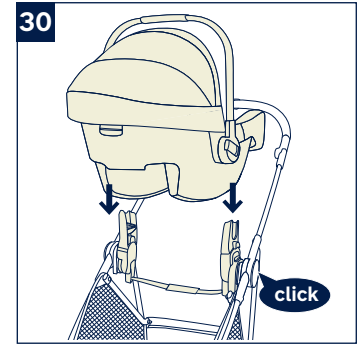
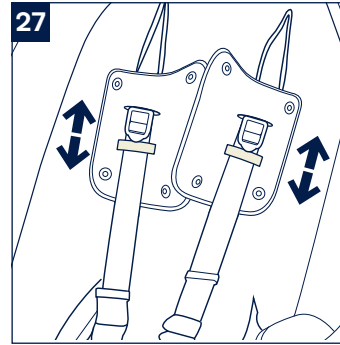
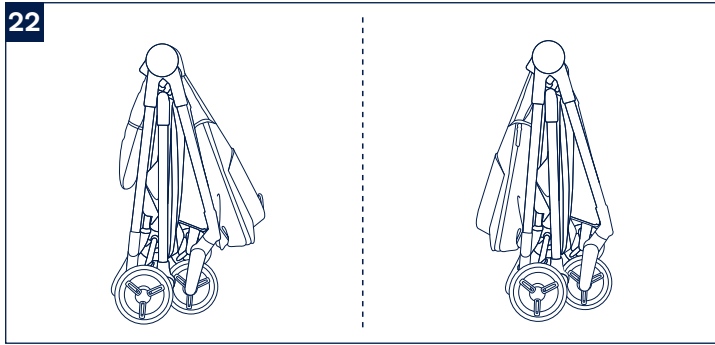

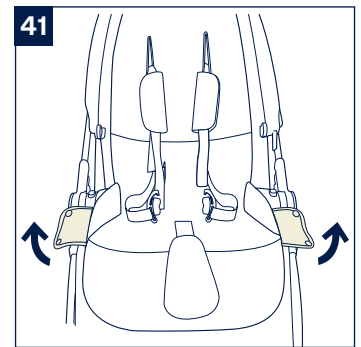
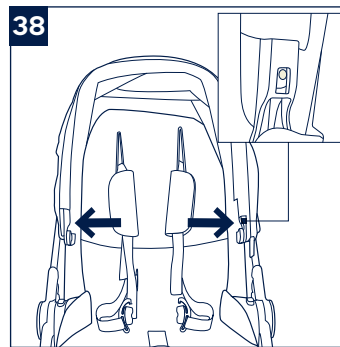
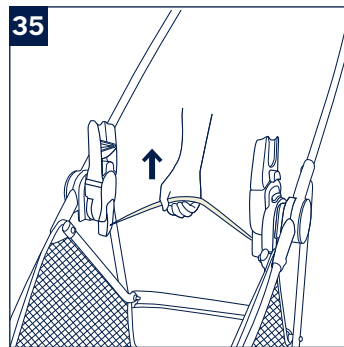
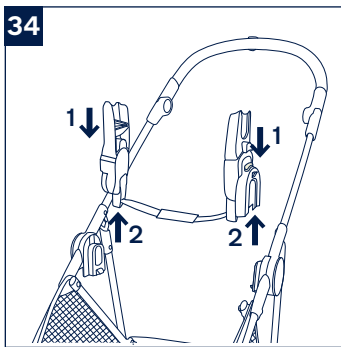
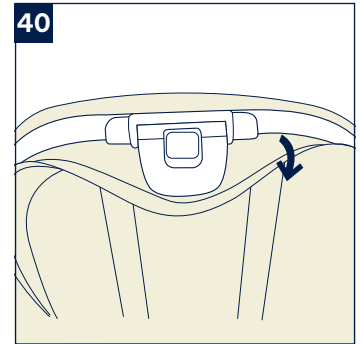
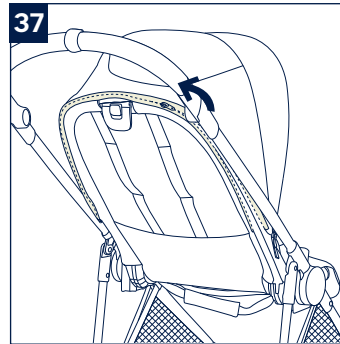
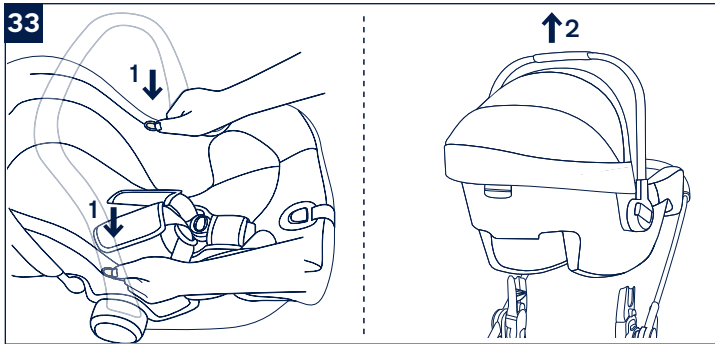
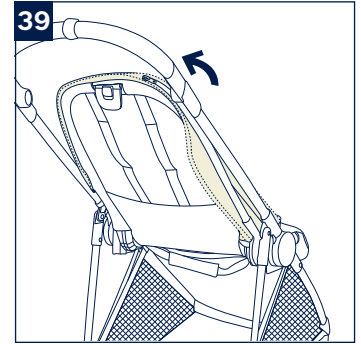
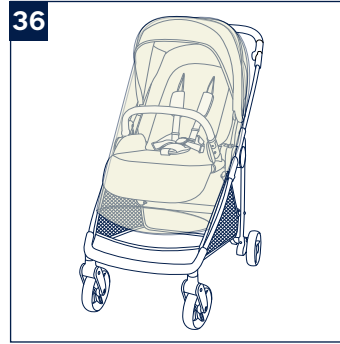
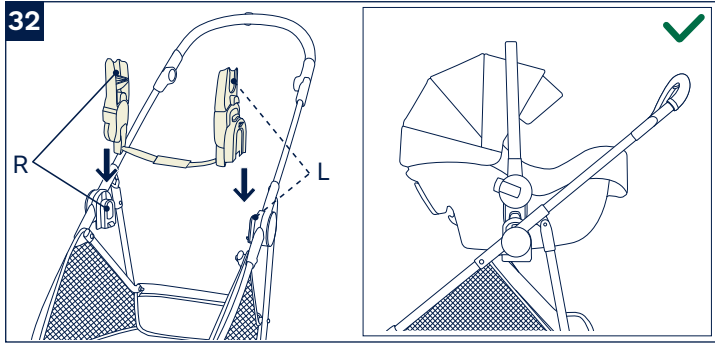

42

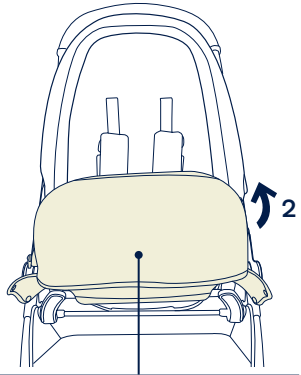

1

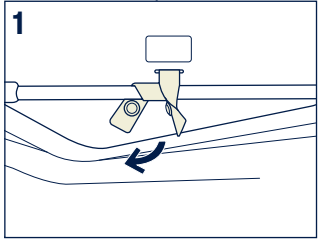

43

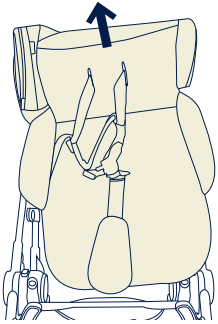

*Designed*  
**around your life**

## 目錄

產品資訊	2
保固與售後服務	
保固條件	
適用範圍	3
警告	4
產品組件及各部位名稱	8
安裝手推車	10
產品使用	11
使用配件	13
拆卸及組裝座布	14
維護與保養	15
English	16



## 產品資訊

產品名稱：\_\_\_\_\_

生產日期：\_\_\_\_\_

### 保固與售後服務

產品於保固期間內發生問題，請與零售商聯絡；若零售商無法提供服務，他們會聯絡當地的Nuna經銷商。產品在正常使用和老化中產生的自然磨損與劣化，並不在保固範圍內。當車輪磨損過度時，請向本公司或代理商聯繫更換(需支付費用)。請留意產品下方的產品型號與生產日期序號。當有保固需求時，請提供以上產品資訊。

請至[www.nunababy.com/tw/gear-registration](http://www.nunababy.com/tw/gear-registration)網站登記您購買的產品。

### 保固條件

保固始於產品購買日，我們提供維修服務，但不提供產品退換。保固期限不會因零件更換或維修而延長。Nuna有權利針對產品進行改善設計，此前製造的產品則無更換義務。相關保固資訊，詳見官網：[www.nunababy.com/tw/warranty](http://www.nunababy.com/tw/warranty)

產品名稱	IXXA 手推車
型號	IXXA next
主要材質	塑膠、鋁合金／五金、布
原產地	中國
製造年份	請見產品上生產日期標(年／月／日)

注意事項及緊急處理方法：

使用本產品時，請詳閱使用說明書及注意事項。

發生意外時，應盡速就醫急救。

## 適用範圍

寶寶需要滿足下列要求

最大體重：15kg

嬰幼兒年齡：0-36個月

當與NUNA汽車椅配合使用，適用範圍請參見該產品說明書。

# 警告

Nuna IXXA 手推車擁有專利並符合臺灣標準  
CNS 12940-2013 和歐盟安全標準  
EN 1888-2:2018+A1:2022 相關規範。

重要：請務必依照產品說明書和警告以避免導致嚴重傷害甚至是死亡事件發生。

- ! 切勿留置嬰幼兒無人照顧。
- ! 使用前，確保所有鎖定裝置皆已嚙合。
- ! 為避免傷害，確保展開與折疊本產品時與兒童保持距離。
- ! 不要讓兒童玩弄本產品。
- ! 務必隨時使用束縛系統。
- ! 使用前查核座椅單元或汽車安全座椅之連接裝置是否正確嚙合。
- ! 本產品僅設計供步行使用。
- ! 為防止事故發生，確保手推嬰幼兒車遠離自動閉合之門(例：在火車或電梯上)。
- ! 此手推車適用於新生兒-15kg嬰幼兒使用。
- ! 供新生兒使用時，應使用最斜躺位置。
- ! 放置與抱起嬰幼兒時，嚙合駐車裝置。
- ! 請勿擺放超過10kg的物件於置物籃，以免導致手推車不穩定而產生危險。
- ! 把手及/或靠背後方及/或手推嬰幼兒車側面的任何掛載將會影響手推嬰幼兒車穩定性。
- ! 一次僅能乘坐一位嬰幼兒。
- ! 未經製造商認可配件不得使用。

- ! 僅限使用製造商/經銷商所提供或建議的替換零件。
- ! 本商品不可放置於機車踏墊使用，亦不可以連結器連接其他手推嬰幼兒車使用。
- ! 嬰幼兒的安全是您的責任。
- ! 為避免手指夾傷問題，收合及展開手推嬰幼兒車時，請務必小心。
- ! 切勿讓嬰幼兒單獨留在手推車內而無人看護。
- ! 請保留說明書以便日後使用。
- ! 六個月大以下的嬰幼兒應同時使用腰部及胯部的安全帶。
- ! 寶寶乘坐時，安全帶或束縛系統必須正確的扣合及使用。
- ! 使用前，請確保汽車椅等裝置正確安裝。
- ! 請勿允許您的嬰幼兒將手推車當玩具玩耍。
- ! 使用前，請確保所有鎖定裝置都已處於鎖定狀態。
- ! 本產品不適用於跑步和滑冰。
- ! 當調整手推車上之任何可活動配件時，必須確定寶寶與手推車保持安全距離。
- ! 保持寶寶遠離遮陽篷/雨篷以免造成窒息。
- ! 請使用Nuna原廠零配件。
- ! 使用前請確定各部件安裝牢固以確保安全。
- ! 停止車台時，手推車務必確實使用制動裝置。
- ! Nuna不保固使用其它廠商提供的零配件所造成的損害。

- ! 任意放置未經製造商核可之物品於車臺上將造成危險。
- ! 不得附載其它的嬰幼兒、物品或配件於推車上。
- ! 不可將手推車放置於馬路、坡道或危險場所。
- ! 寶寶乘坐於手推車內時，不可將整個手推車往上提。
- ! 使用時請扣好安全帶，以免寶寶滑入腿部開口外而造成窒息。
- ! 使用時請遠離火源、高溫、水池或電源之附近範圍。
- ! 請勿在遮陽篷上放置任何物品。
- ! 請勿將產品放置潮濕的環境中。請自然風乾手推車上的布料，並避免使用直接熱源烘乾。
- ! 請勿將嬰幼兒放到置物籃內。
- ! 如果有任何零件損壞，磨破或丟失，請停止使用該產品。
- ! 當嬰幼兒需睡眠時，請將之放置於合適的嬰兒床。
- ! 為避免窒息危險，請將小零件存放到嬰幼兒接觸不到的地方。
- ! 請注意在粗糙地面使用時，反復衝擊會損壞手推嬰兒車。
- ! 不可讓嬰幼兒站立。
- ! 座位不得乘坐一位以上嬰幼兒或附載其它物品於推車上。
- ! 禁止在樓梯上使用手推車。
- ! 安全帶或束縛系統必須正確的扣合及使用。且安全帶與束縛系統的使用，不能取代成人的看護。

- ! 嬰幼兒放入或抱出手推車時，務必確認剎車已處於鎖定狀態。
- ! 使用前應確實豎立及固定各機構以確保安全。
- ! 超載、不正確的收合、使用非經核准的零配件都可能造成手推嬰兒車損壞、故障或不安全，請務必閱讀說明書。
- ! 輪胎可能會在某些表面留下黑色痕跡，特別是光滑的表面，像木地板、合層板和亞麻油地板。
- ! 請勿將任何繩索或索帶類物件懸掛於嬰幼兒頸部附近，或扣在產品及玩具上，以免導致嬰幼兒意外窒息。
- ! 使用手推車之前，請務必去掉、銷毀或是將所有附加包裝遠離嬰幼兒，以防嬰幼兒窒息。
- ! 乘載超過15kg的重量，將會導致手推車的重度磨損以及過重的負荷。
- ! 當結合汽車椅使用時，本產品不可代替睡床使用。若您的寶寶需要睡眠時，請讓寶寶睡在合適的睡床上。
- ! 安全帶扣具組含有磁鐵，會影響某些醫療器材的運作。若您的孩子有使用這類醫療器材，禁止磁鐵靠近孩子與醫療器材，請勿使用此推車。請與Nuna聯繫進一步討論方案。
- ! 請注意安全帶扣具組中的磁鐵可能與某些電子設備產生作用。

# 產品組件及各部位名稱

組裝前請確認所有部件已經齊全。如有遺漏，請與銷售商聯繫。本產品無需工具進行組裝。

- |            |           |
|------------|-----------|
| 1 手推車架     | 12 座椅卡合按鈕 |
| 2 小座墊      | 13 安全扣    |
| 3 汽車椅卡座    | 14 肩帶護片   |
| 4 遮陽篷      | 15 車手調整按鈕 |
| 5 座墊       | 16 扶手     |
| 6 扶手       | 17 車手     |
| 7 小腿靠      | 18 剎車踏板   |
| 8 前輪(x2)   | 19 收合織帶   |
| 9 後輪(x2)   | 20 背靠調整按鈕 |
| 10 置物籃     | 21 座椅收合按鈕 |
| 11 小腿靠調整按鈕 | 22 雨篷     |

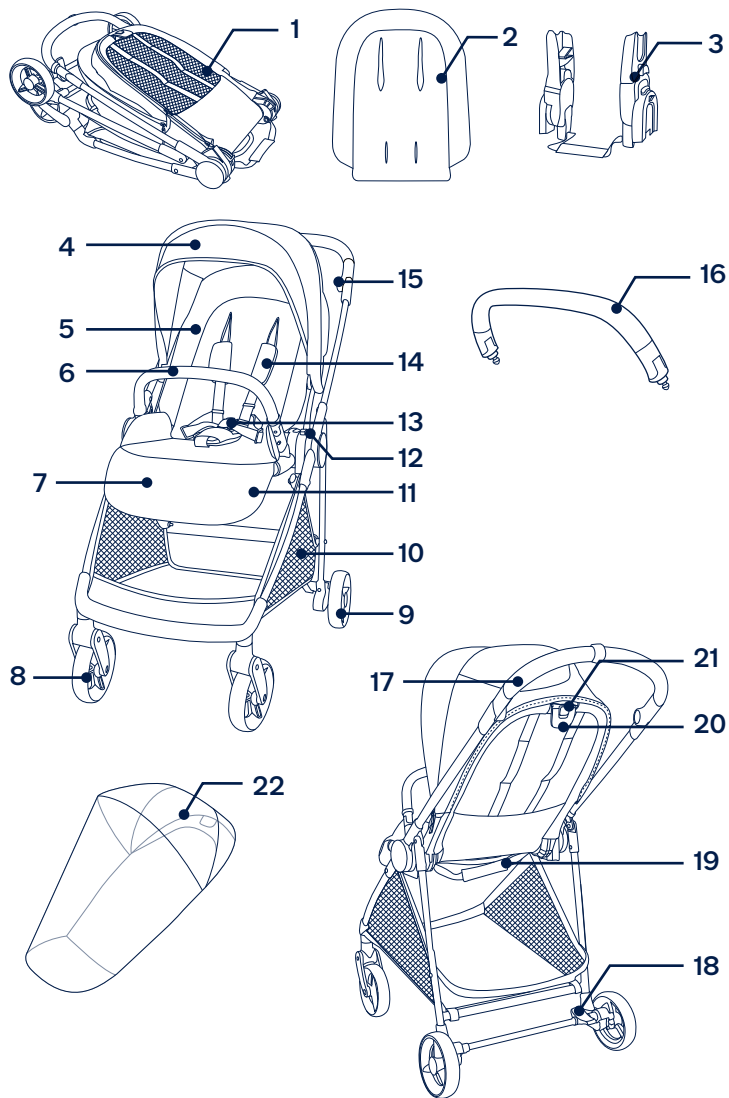

## 安裝手推車

### 打開手推車

- 1- 向上拉起車手以打開手推車架(1)
- 2- 將座椅打開(2)，聽到“咔嚓”聲表示座椅已完全打開。

### 座椅換向

座椅可隨使用需求換向。

- 1- 按下座椅卡合按鈕(3)-1並提起座椅(3)-2
- 2- 將座椅換向後接合於車架(4)，聽到“咔嚓”聲表示座椅已完成接合。

### 安裝扶手

- 1- 將扶手卡槽對準扶手座插入，聽到“咔嚓”聲表示扶手已安裝完成(5)
- 2- 按壓扶手兩側釋鎖按鈕(6)-1，兩側同時向外拉即可拆卸扶手(6)-2

## 產品使用

### 使用安全扣

- 1- 按下母扣上方的按鈕(7)-1，安全扣會自動鬆開，將寶寶放入手推車(7)-2
- 2- 將肩帶及腰部扣環與母扣結合(8)
- 3- 滑動織帶（在肩帶護片下方）調整織帶長度(9)-1，拉緊腰部織帶(9)-2，使寶寶更加舒適。

### 調整肩帶位置

- 1- 肩帶固定栓可上下滑動調整至適當位置(10)
- ！請確保安全帶已適當調整，寶寶與安全帶間的空隙約為一隻手指寬。

### 使用遮陽篷

- 1- 打開遮陽篷，請將遮陽篷推向前方。折疊遮陽篷，請將遮陽篷拉向後方(11)
- 2- 遮陽篷中段拉鍊可打開以延伸遮陽篷範圍(12)

### 調整小腿靠

小腿靠共有3種角度可供調節。

- 1- 段位調高時，將小腿靠支撐板由下往上推即可(13)
- 2- 段位調低時，按壓小腿靠兩側的調整按鈕(14)-1，同時向下調節小腿靠支撐板(14)-2

## 調整背靠

背靠可3段角度調節。

- 1- 調高或調低背靠角度，請按壓背靠調整按鈕(15)-1，向上或向下調整至所需的背靠角度(15)-2

！ 調整背靠高度時，請勿按壓(15)-3位於背靠調整按鈕中央的按鈕。

## 使用剎車

- 1- 剎車時，踩下剎車踏板后端(16)
- 2- 打開剎車時，踩下剎車踏板前端(17)

## 調整手把

！ 手把可分3段式調整。

- 1- 如要調整手把，請同時按下左右手把調整鈕，然後將手把調整至所需位置(18)

收合手推車之前，請先將手把調至第二段位置。手推車收合後可立起。

## 收合手推車

此手推車在座椅前向或後向時皆可收合。

- 1- 收攏遮陽篷
- 2- 按壓背靠調整按鈕中間的座椅收合按鈕(19)-1，並按壓背靠調整按鈕(19)-2
- 3- 折疊座椅(20)
- 4- 拉起收合織帶，收合手推車(21)
- 5- 手推車收合後可站立(22)

- 6- 收合無安裝座椅的手推車，按壓椅座的收合鈕(23)，手推車架可以收合站立(24)

## 小座墊

- 1- 安裝小座墊，請將小座墊置於座椅並將肩帶及腰帶從小座墊的對應孔穿出(25)

## 使用肩帶護片和胯帶護片

- 1- 肩帶護片和胯帶護片可從織帶上取下，反之即可組裝(26)-(28)

## 使用配件

因產品型號的不同，並非所有手推車均附以下配件。

## 汽車椅卡座

當與Nuna汽車椅組裝與使用請參考相關使用說明書。

- 1- 安裝汽車椅卡座，放置卡座於座椅底座上。聽到“咔嚓”聲表示卡座已安裝完成(29)
- 2- 安裝汽車椅，放置於卡座上，聽到“咔嚓”聲表示已卡合到位(30)
- 3- 汽車椅可以通過可調整的卡座進行調整(31)
- 4- 當使用後向卡合，汽車椅卡座上的L與車架釋鎖按鈕上的L相對應(32)
- 5- 移除汽車椅，按壓汽車椅釋鎖按鈕(33)-1，同時向上提起汽車椅即可(33)-2
- 6- 移除汽車椅卡座，按壓卡座的釋鎖鈕(34)-1，並向上提起汽車椅卡座(34)-2

## 使用汽車椅卡座的收合方式

- 1- 拉起汽車椅卡座上的收合織帶以收合手推車(35)

### IXXA next 座椅雨篷

安裝雨篷前，請確認雨篷已完全展開。

- 1- 將雨篷套到座椅上(36)

## 拆卸及組裝座布

拆卸座布請參照說明書(37)-(43)，若需組裝座布，請反向操作上述步驟。

## 維修與保養

可用濕布清潔車架和座布，請勿使用研磨劑或漂白劑。請勿使用潤滑劑，因為它們會吸附灰塵和污垢。請勿將手推車儲存在潮濕的地方。

請定期以水清洗輪子，並清除污垢。

為使手推車能長期使用，下雨天使用後，請用軟質可吸水的布擦拭手推車。

請參考手推車上洗滌標的洗滌方式。

長期使用之後，在正常狀況下，座布可能產生褪色、磨損或撕裂。

為確保安全，請使用Nuna原廠零配件。

請定期檢查您的手推車功能是否正常與零件是否鬆弛磨損或脫落。一旦發生以上任何狀況，請立即停止使用本手推車。

請隨時檢查束縛系統的日字扣，扣具和整個安全帶(包括任何點)是否完好無損。

如有任何磨損，裂紋或破損情況。請立即停止使用。

**IMPORTANT!  
READ CAREFULLY  
AND KEEP FOR  
FUTURE REFERENCE**

## Contents

<b>Product Information</b>	18
Product Registration	
Warranty	
<b>Child Usage Requirements</b>	18
<b>Warnings</b>	19
<b>Parts List</b>	22
<b>Product Set Up</b>	24
<b>Product Use</b>	25
<b>Accessories</b>	27
<b>Detach &amp; Assemble Soft Goods</b>	29
<b>Cleaning and Maintenance</b>	29

## Product Information

Model Number: \_\_\_\_\_

Manufactured Date: \_\_\_\_\_

### Product Registration

Please fill in the above information. The model number and the manufactured date are located on a label on the stroller frame.

To register your product please visit:

[www.nunababy.com](http://www.nunababy.com)

Click the “Register Gear” link on the homepage.

### Warranty

We have purposely designed our high-quality products so that they can grow with both your child and your family. Because we stand by our product, our gear is covered by a custom warranty per product, starting from the day it was purchased. Please have the proof of purchase, model number and manufactured date available when you contact us.

For warranty information please visit:

[www.nunababy.com](http://www.nunababy.com)

Click the “Warranty” link on the homepage.

## Child Usage Requirements

This stroller seat is suitable for use with children who meet the following requirements:

Birth to 15 kg or 3 years whichever comes first in each seat.

When using the stroller frame with NUNA infant carrier, refer to the child usage requirements listed in the infant carrier instruction manual.

## **⚠️**WARNING

Failure to follow these warnings and instructions could result in serious injury or death.

Always use the restraint system.

Check that the pram body or seat unit or car seat attachment devices are correctly engaged before use.

Do not let the child play with this product.

Ensure that all the locking devices are engaged before use.

Never leave the child unattended.

This product is not suitable for running or skating.

To avoid injury ensure that the child is kept away when unfolding and folding this product.

Accessories which are not approved by the manufacturer shall not be used. Only replacement parts supplied or recommended by the manufacturer/distributor shall be used.

Adult assembly required.

Any load attached to the handle and/or on the back of the backrest and/or on the sides of the vehicle will affect the stability of the vehicle.

**DO NOT** carry additional children, goods, accessories in or on the stroller except as permitted in this manual. They may cause the stroller to become unstable.

**DO NOT** leave the stroller exposed in the vicinity of a strong source of heat i.e. a radiator or open fire.

**DO NOT** place any item on the canopy.

**DO NOT** store the stroller in a damp place. Always allow the fabric to dry naturally away from direct heat.

**DO NOT** use storage basket as a child carrier.

**DO NOT** use the stroller if any parts are damaged or missing.

For car seats used in conjunction with a chassis, this vehicle does not replace a cot or a bed.

Keep small parts away from children as they pose a choking hazard.

Negotiate curbs and rough ground carefully. Repeated impact could cause damage to the stroller.

**NEVER** allow children to stand on the stroller.

**NEVER** use the stroller on stairs or escalators. You may suddenly lose control of the stroller or your child may fall out.

Overloading, incorrect folding, and the use of accessories e.g. child seats, bag hooks, rain covers, buggy boards, etc... other than those approved by Nuna may damage or make the stroller unsafe.

**STRANGULATION HAZARD** Do not place items with a string around your child's neck, suspend strings from this product, or attach strings to toys.

To avoid any danger of suffocation, remove all plastic covers before using this item and destroy or keep away from babies and children!

To prevent a hazardous, unstable condition, do not place more than 10 kg in the storage basket.

**ALWAYS** check ventilation when the rain cover is on the product.

**ALWAYS** check that the rain cover has been cleaned and dried before folding.

**DO NOT** fold the pushchair when the rain cover is attached.

**DO NOT** place your child in the pushchair in hot weather with the rain cover attached.

**Magnetic Harness Buckle:** The buckle and buckle clips contain magnets. If your child has a medical condition that prohibits the use of magnets near the child, do not use the stroller. Contact Nuna to discuss a solution.

Be mindful of the possible interaction of magnets in buckles and certain electronic devices.

# Parts List

Make sure all parts are available before assembly. If any part is missing, please contact local retailer. No tools are required for assembly.

- |                                   |                              |
|-----------------------------------|------------------------------|
| 1 Stroller Frame                  | 12 Seat Release Button       |
| 2 Insert                          | 13 Buckle                    |
| 3 Post Adapters                   | 14 Shoulder Harness Pad      |
| 4 Canopy                          | 15 Handle Button             |
| 5 Seat Pad                        | 16 Arm Bar                   |
| 6 Arm Bar                         | 17 Handle                    |
| 7 Calf Support                    | 18 Brake Lever               |
| 8 Front Wheel (x2)                | 19 Folding Webbing           |
| 9 Rear Wheel (x2)                 | 20 Recline Adjustment Button |
| 10 Storage Basket                 | 21 Folding Release Button    |
| 11 Calf Support Adjustment Button | 22 Rain Cover                |

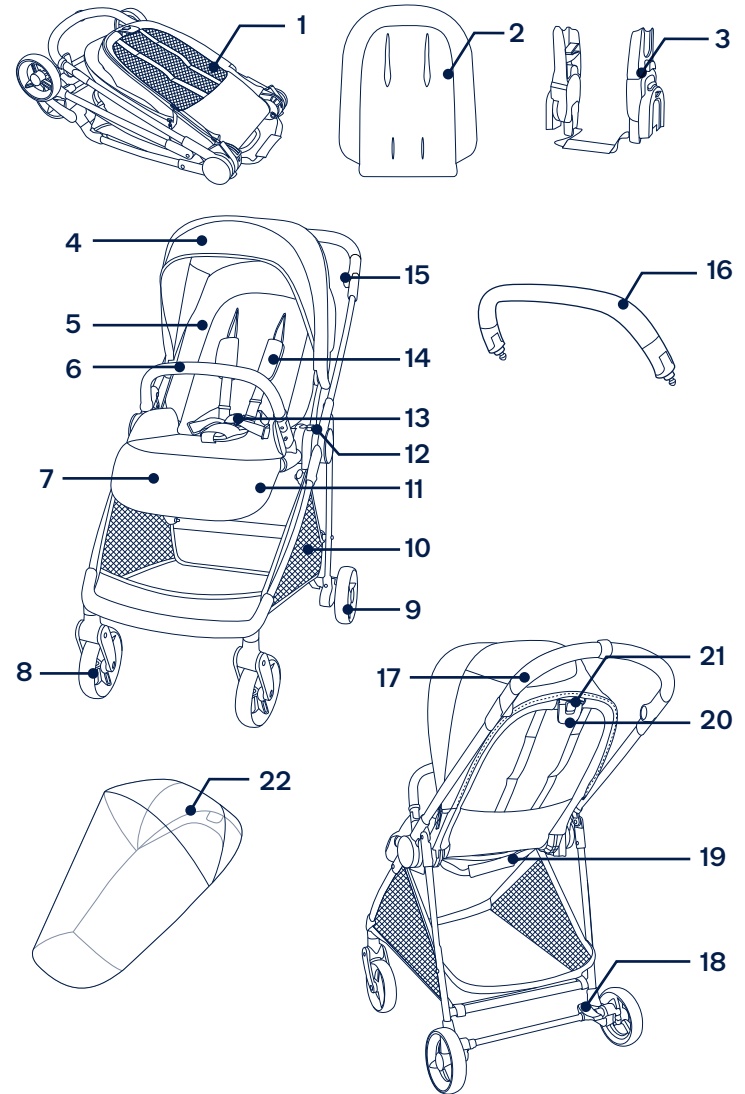

## Product Set Up

### Open Stroller

- 1 - Rotate the handle up to open the stroller frame. **(1)**
- 2 - Pull the seat to open it. **(2)** A “click” sound means the seat is open.

### Switch Seat

Please switch seat if you needed.

- 1 - Press the seat release button **(3)-1** and lift the seat up **(3)-2**.
- 2 - Reverse the seat, and then attach it to the frame. **(4)**  
A “click” sound means the seat is attached completely.

### Arm Bar

- 1 - Align the arm bar ends with the arm bar mounts, and insert until it clicks into place. **(5)**  
A “click” sound means the arm bar is assembled completely.
- 2 - To remove the arm bar, press the arm bar release buttons **(6)-1** and remove the arm bar **(6)-2**.

## Product Use

### Securing Your Child

- 1 - Push the top button on the buckle **(7)-1** to release the buckle latch and remove the magnetic clips **(7)-2**. Place your child in the stroller.
- 2 - Insert the magnetic clips into the buckle. **(8)**
- 3 - Fit the harness snugly to your child by pulling the adjustment straps to tighten **(9)-1**. Then pull the waist adjustment straps out **(9)-2**.

### Shoulder Harness Position

- 1 - The upper shoulder harness buckles can be moved up and down for added adjustment. **(10)**

Make sure the harness is adjusted properly and your child is snugly secured. The space between the child and the shoulder harness should be about the thickness of one finger.

### Canopy

- 1 - To open the canopy, pull the canopy toward the front of the seat, and to fold, push it back. **(11)**
- 2 - Open the zipper on the canopy for extra shade. **(12)**

### Calf Support

The calf support has 3 use positions.

- 1 - To raise calf support, push the calf support from position 1 to position 3. **(13)**
- 2 - To lower calf support, press two adjustment buttons on the bottom of the calf support **(14)-1**, and rotate the calf support downwards. **(14)-2**.

## Recline

There are 3 recline positions for the backrest.

- 1 - To raise or lower the backrest, squeeze the recline adjustment button **(15)-1**, and pull the backrest up or down **(15)-2**.

! Please do not press the button **(15)-3** on the middle of the recline adjustment button when adjusting the angle for the recline.

## Brake

- 1 - To lock wheels, step the rear end of the brake lever downwards. **(16)**
- 2 - To release wheels, step the front end of the brake lever downwards. **(17)**

## Adjust Handle

Handle can be adjusted to 3 positions.

- 1 - To adjust the handle, press the left and right handle adjustment buttons at the same time, and rotate the handle to a desirable position. **(18)**

Before folding the stroller, please adjust the handle to the second position. The stroller can stand after folding.

## Fold

The stroller can be folded with forward facing seat or rear facing seat or without the seat.

- 1 - Fold the canopy.
- 2 - Press the folding release button **(19)-1** on the middle of the recline adjustment button and then squeeze the recline adjustment button **(19)-2**.

- 3 - Fold the seat. **(20)**

- 4 - Pull the folding webbing of the seat to fold the stroller. **(21)**

- 5 - The stroller can stand after folded. **(22)**

- 6 - Fold the stroller without seat on it, press the folding buttons of the seat mounts. **(23)** The stroller frame can stand by handle and the rear wheels. **(24)**

## Insert

- 1 - To assemble the insert, place the insert over the seat, then thread the shoulder and waist harnesses through their respective slots. **(25)**

## Shoulder Harness Cover and Crotch Harness Cover

- 1 - The shoulder harness cover or crotch harness cover can be removed from the webbing. To assemble shoulder harness cover and crotch harness cover in reverse steps. **(26)-(28)**

## Accessories

Not all accessories are included on some models.

### Post Adaptors

For Nuna infant carrier, assembly and usage, please refer to the infant carrier instruction manual.

- 1 - To attach the post adaptors, place the post adaptors on the seat mounts. A “click” sound means the post adaptors are attached. **(29)**

- 2 - To attach infant carrier, place the infant carrier on the post adapters. A “click” sound means the infant carrier is attached. **(30)**
- 3 - The infant carrier angle can be adjusted with our adjustable adaptors. **(31)**
- 4 - When used with rear facing, the letters on the post adaptors are the same as those on the frame plastic. **(32)**
- 5 - To remove the infant carrier, push the release buttons on the infant carrier **(33)-1** and lift up **(33)-2**.
- 6 - To remove the post adapters, press the adapter release buttons **(34)-1** and lift up **(34)-2**.

### **Fold the Stroller with Post Adapters**

- 1 - Pull the folding webbing of the post adapters to fold the stroller. **(35)**

### **IXXA next Rain Cover**

Check that the canopy is completely open before attaching the rain cover.

- 1 - To assemble the rain cover, place it over the pushchair. **(36)**

## **Detach & Assemble Soft Goods**

To detach seat soft goods, follow the steps **(37) - (43)** as shown, and to re-assemble seat soft goods, follow the steps above in reverse.

## **Cleaning and Maintenance**

Clean the frame, plastic parts, and fabric with a damp cloth, but do not use abrasives or bleach. Do not use silicon lubricants as they will attract dirt and grime. Do not store your stroller in a damp place.

Clean the stroller wheels regularly with water and remove any dirt.

To ensure long-lasting use, wipe the stroller off with a soft, absorbent cloth after using it in rainy weather.

Refer to the care label attached to the soft goods for washing and drying instructions.

It is normal for fabric to color from sunlight and to show wear and tear after a long period of use, even when used normally.

For reasons of safety, only use original Nuna parts.

Check regularly if everything functions properly. If any parts are torn, broken, or missing, stop using this product.



