

Designed
around your life

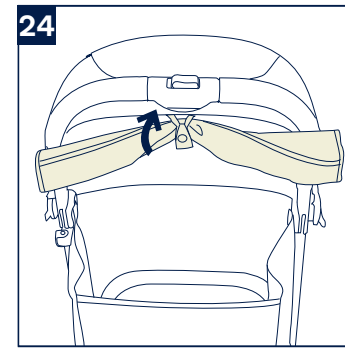

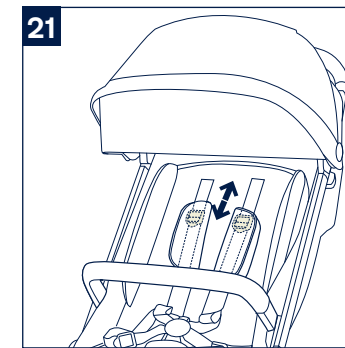
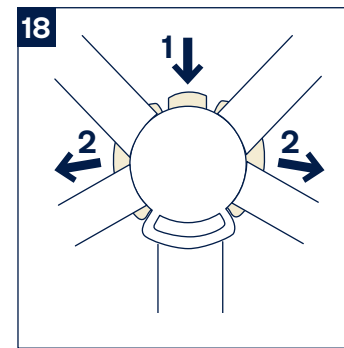
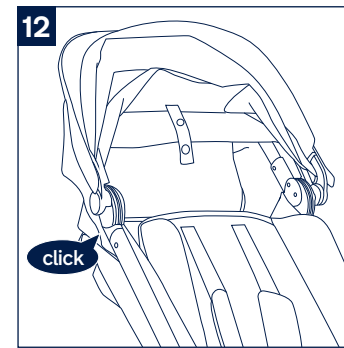
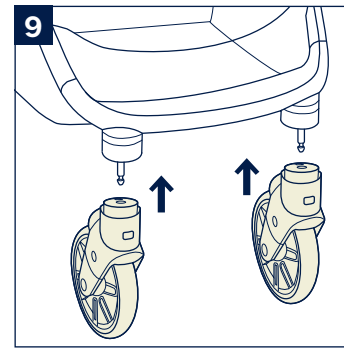
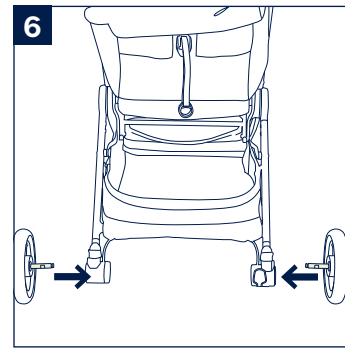
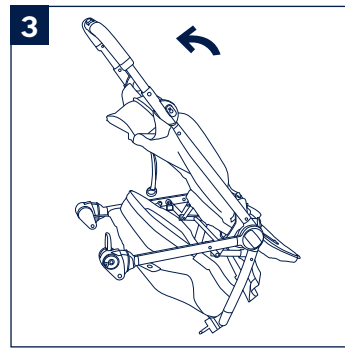
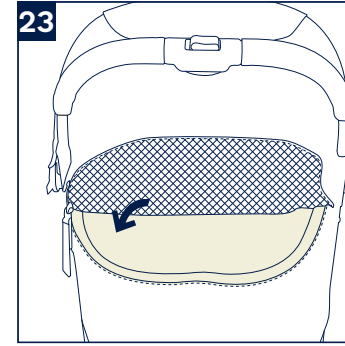
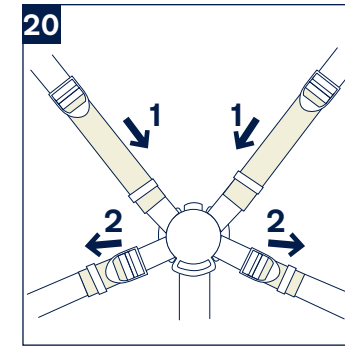
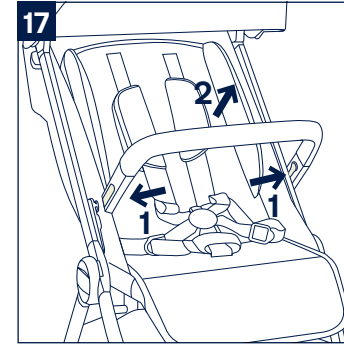
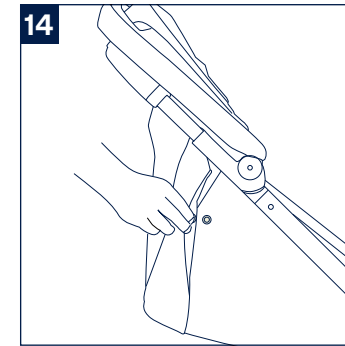
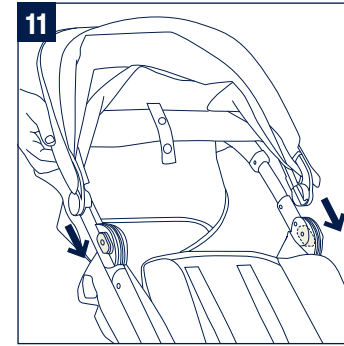
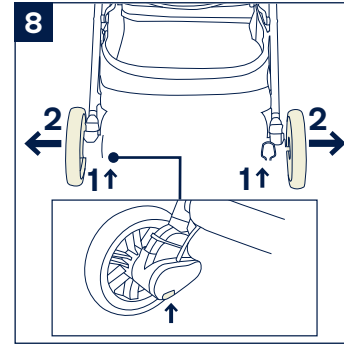
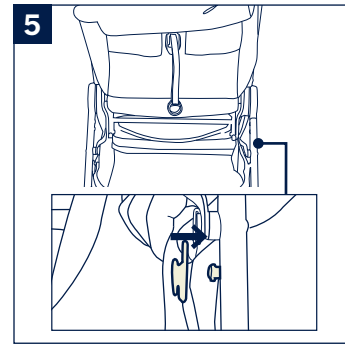
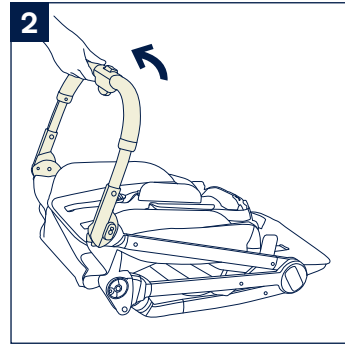
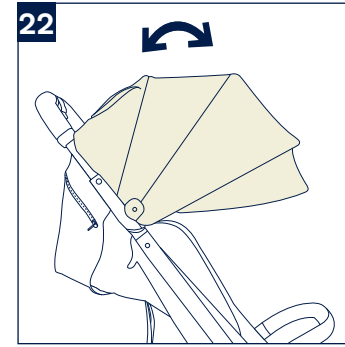
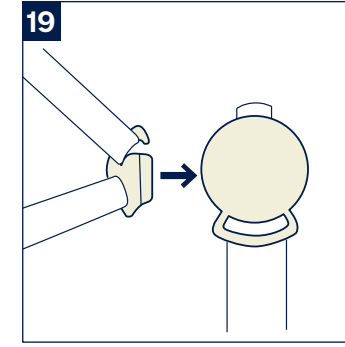
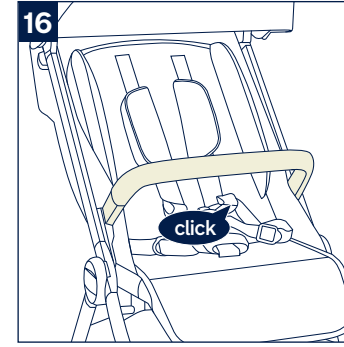
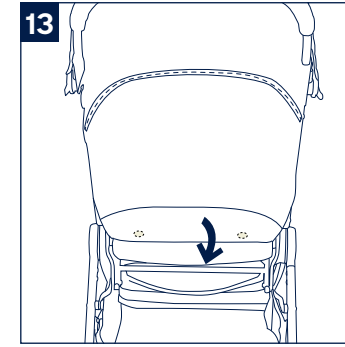
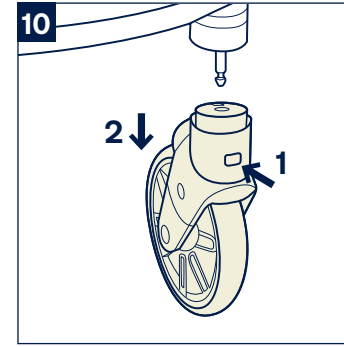
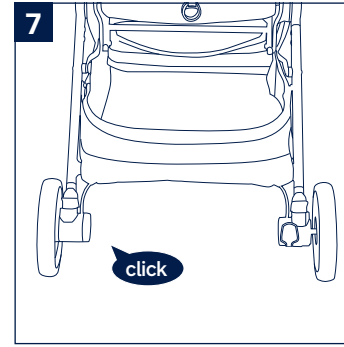
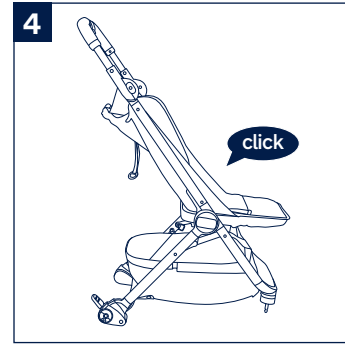
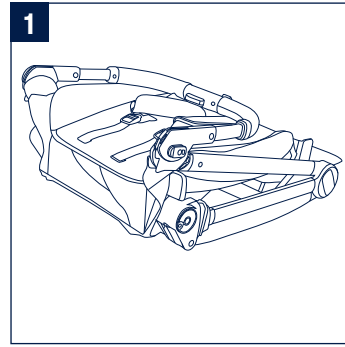
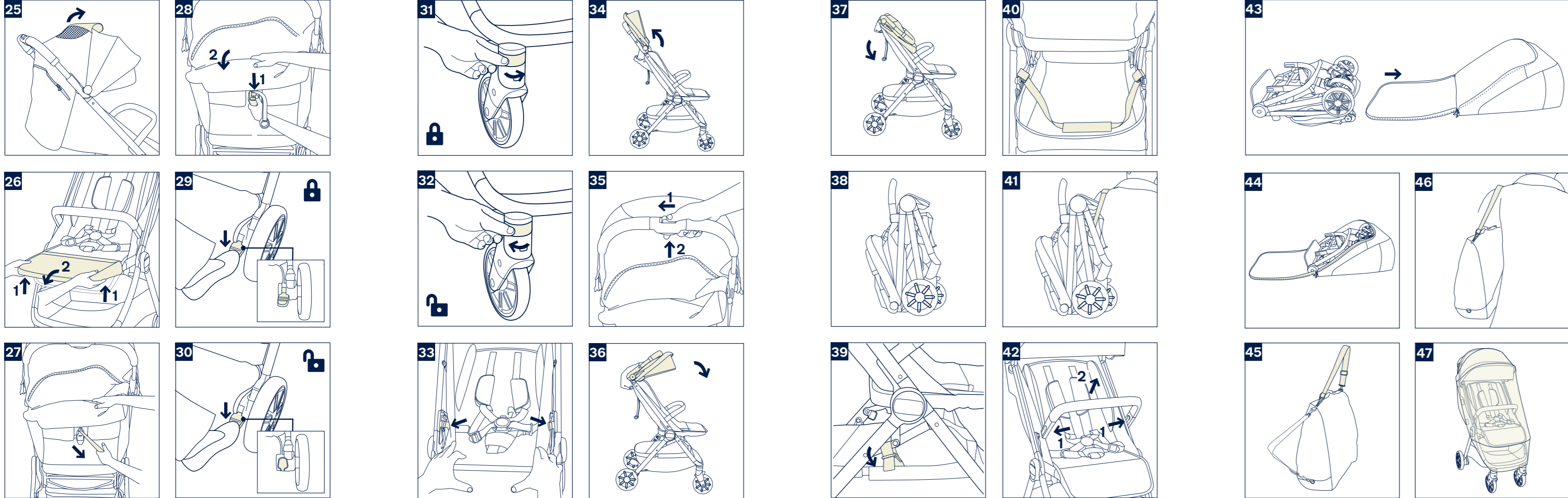

**请妥善保存本说明书
以备不时之需!**

使用产品前请仔细阅读本说明书，
并妥善保存以便日后参照。不依照
本说明书的指示操作，可能会影响到您
宝宝的安全。

目录

产品资讯	3
保修与售后服务	3
保修条件	3
联络我们	3
适用范围	4
警告	5
产品组件及各部件名称	9
安装手推车	11
产品使用	13
使用配件	16
使用雨篷	16
维修与保养	17
English	19

产品资讯

产品名称：_____

生产日期：_____

保修与售后服务

产品于保修期间内发生问题，请与零售商联络；若零售商无法提供服务，他们会联络当地的Nuna经销商。请留意产品车架上的产品型号与生产日期序号。当有保修需求时，请提供以上产品资讯。请至www.nunababy.com网站登记您购买的产品。

保修条件

保修始于产品购买日，我们提供维修服务，但不提供产品退换。保修期限不会因零件更换或维修而延长。Nuna有权利针对产品进行改善设计，此前制造的产品则无更换义务。

相关保固资讯，详见官网：

www.nunababy.com

联络我们

我们期望不断改进并开发新的产品，请随时告知您对Nuna产品的意见和建议。

info@nunababy.com

www.nunababy.com

制造商： NUNA International B.V.
地址： Van der Valk Boumanweg 178 C
2352JD Leiderdorp
The Netherlands

品名： TRVL 手推车
型号： ST15703MDWCH、ST15704SAPCH
主要材质： 塑胶、铝合金/五金、布
执行标准： GB 14748-2006 《儿童推车安全要求》

产地： 中国
生产企业： 明门(中国)婴童用品有限公司
地址： 广东省东莞市清溪镇银湖工业区

适用范围

宝宝需要满足下列要求：

重量： 新生儿-22kg

年龄： 0-48个月

警告

Nuna TRVL 手推车拥有专利并符合国家安全标准 GB 14748-2006 《儿童推车安全要求》

- ! 重要:请务必依照产品说明书和警告以避免导致严重伤害甚至是死亡事件发生。
- ! 宝宝的安全是您的责任。
- ! 本产品须由成人进行组装。
- ! 当儿童乘坐时, 看护人不要离开。
- ! 在把手上放置任何负载会影响车辆的稳定性。
- ! 使用推车前确保所有锁定装置都已处于锁定状态。
- ! 儿童乘坐时必须使用安全带。
- ! 当放置儿童于车内或从车中抱出儿童时应启用制动装置。
- ! 本产品适用于刚出生及体重不超过22公斤的宝宝使用。
- ! 产品一次只能乘坐一个宝宝。
- ! 本手推车置物篮承载重量不能超过4.5公斤。
- ! 6个月以下宝宝使用时, 必须使用最斜躺位置。

- ! 安全带或束缚系统必须正确的扣合及使用。
- ! 本产品不适合在跑步或溜冰时使用。
- ! 使用手推车之前, 请务必去掉、销毁或是将所有附加包装远离宝宝, 以防止宝宝窒息。
- ! 使用时必须配用束缚系统。
- ! 固定好扣具之后请调整安全带确保宝宝处于最舒适的状态。使用安全带并不能取代成人的监督。
- ! 停放手推车时, 请使用刹车。
- ! 禁止在上下楼梯 / 手扶梯时使用手推车。
- ! 请勿放置另外的物品或配件在手推车上, 可能影响其手推车的稳定性。
- ! 顶篷上不得放置任何物品。
- ! 超重、不正确收合或使用非Nuna原厂的配件可能导致车台损坏与不安全。
- ! 禁止使用非生产商提供的附件, 请使用Nuna原厂零配件。

- ! 本手推车保修条件不适用于任何因使用其他厂商配件造成本产品的损坏。
- ! 不可让宝宝站立或倒坐于手推车上。
- ! 本手推车若有任何零件、部位遗失或损坏，应立即停止使用。
- ! 行经护栏与粗糙路面时务必小心。重复撞击力可能对手推车造成坏损。
- ! 请勿将手推车放置于马路、坡道或危险场所。
- ! 宝宝乘坐于手推车内时，请勿将整个手推车往上提。
- ! 使用时请远离火源、高温、水池或电源之附近范围。
- ! 保持宝宝远离遮阳篷或雨篷以免造成窒息。
- ! 当调整手推车上之任何可活动配件或背带时，必须确定宝宝与手推车或背带保持安全距离。
- ! 本手推车轮胎行经光滑表面(如拼花地板、薄地板和油布地毯)时，可能会留下黑色胎痕。
- ! 请将手推车放置于阴凉干燥处，让手推车座布自然风干。

- ! 为避免窒息危险，请将小零件存放到宝宝接触不到的地方。
- ! 请勿允许您的宝宝将手推车当玩具玩耍。
- ! 使用时请扣好安全带，以免宝宝滑入腿部开口外而造成窒息。
- ! 遇紧急事故时，迅速将乘坐的儿童移离现场。
- ! 不使用肩背方式时，应确实将肩背带收好，使婴幼儿无法接触。

产品组件及各部件名称

组装前请确认所有部件已经齐全，如有遗漏，请与销售商联系。本产品无需工具进行组装。

！窒息危险：务必去掉、丢弃每个车轮或轮轴的保护套。

- | | |
|------------|-----------|
| 1 手推车架 | 15 第二道安全锁 |
| 2 扶手 | 16 车手 |
| 3 前轮 (x2) | 17 单手按钮 |
| 4 后轮 (x2) | 18 背靠调整按钮 |
| 5 遮阳篷 | 19 置物篮 |
| 6 扶手 | 20 后轮释锁按钮 |
| 7 小腿靠 | 21 刹车踏板 |
| 8 脚踏板 | 22 后轮 |
| 9 前轮定向锁 | 23 天窗 |
| 10 前轮释锁按钮 | 24 肩背带 |
| 11 前轮 | 25 遮阳篷 |
| 12 小腿靠调整按钮 | 26 雨篷 |
| 13 安全扣 | 27 置物袋背带 |
| 14 肩带护片 | 28 置物袋 |

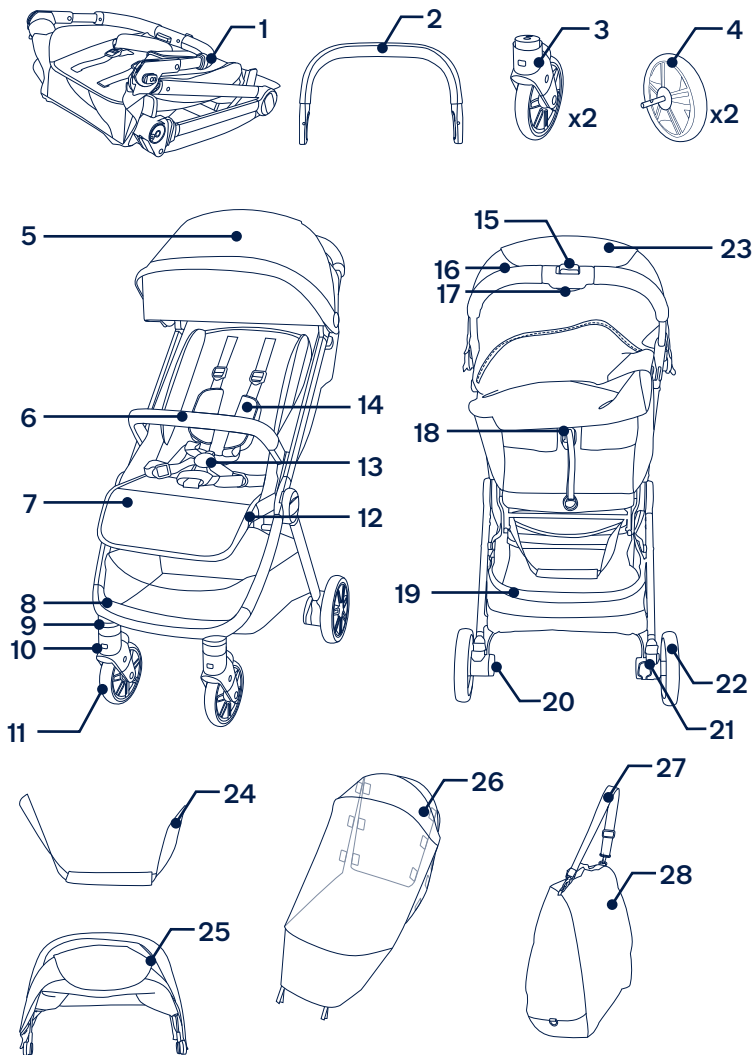

安装手推车

打开手推车

- 1- 取出手推车车架(1)
- 2- 向上拉起车手(2)，打开手推车(3)(4)
- 3- 听到“咔哒”声表示车架已完全打开。使用手推车前请务必确保车架已打开到位。

安置物篮

将置物篮的挂钩挂在两边的后脚管上(5)

安装后轮

- 1- 将后轮套入后脚(6)，听到“咔哒”声表示后轮已安装到位(7)。往外轻拉，确定后轮已正确安装。
- 2- 按压后轮释锁按钮(8)-1，同时向外拉(8)-2，即可移除后轮。

安装前轮

- 1- 将前轮套入前脚(9)，听到“咔哒”声表示前轮已安装到位。往外轻拉，确定前轮已正确安装。
- 2- 按压前轮释锁按钮(10)-1，同时向下拉(10)-2，即可拔出前轮。

安装遮阳篷

- 1- 将遮阳篷两边插入车架上(11)，听到“咔哒”声表示遮阳篷已安装完成(12)
- 2- 将遮阳篷后片的纽扣固定在背靠上(13)(14)

安装扶手

！ 宝宝乘坐时必须系上安全带，扶手并不能确保宝宝的安全。

- 1- 将扶手卡槽对准扶手座插入(15)，听到“咔哒”声表示扶手已安装完成(16)
- 2- 按压扶手两侧释锁按钮(17)-1，同时向外拉即可拆卸扶手(17)-2

检查

- 手推车车架已完全展开
- 前、后轮已确实安装
- 扶手已确实安装

产品使用

使用安全扣

- ！ 为了防止宝宝摔跤，宝宝乘坐时必须系上安全带。
- ！ 请牢牢地系上安全带，并注意宝宝与安全带之间须可以放进一个手掌的厚度。
- ！ 请勿交叉肩带，以免对宝宝颈部造成压迫。
- 1- 按下母扣上的按钮，安全扣会自动松开(18)
- 2- 将肩带扣插入腰带扣，再将他们插入母扣内会自动扣合(19)，听到“咔哒”声表示扣合到位。
- 3- 滑动织带以调整肩带长度(20)-1，拉紧腰部织带(20)-2，使宝宝更加舒适。

调整肩带位置

肩带固定栓可上下滑动调整至适当位置(21)

使用遮阳篷

- 1- 打开遮阳篷，请将遮阳篷推向前方。折叠遮阳篷，请将遮阳篷拉向后方(22)
- 2- 拉开拉链可打开遮阳篷后片(23)

3- 遮阳篷后片可卷起并扣住，便于随时留意宝宝(24)

4- 遮阳篷天窗可打开增加透气性(25)

调整小腿靠

小腿靠共有两种角度可供调节。

- 1- 段位调高时，将小腿靠由下往上推即可。
- 2- 段位调低时，按压小腿靠两侧的调整按钮(26)-1，同时向下调节小腿靠(26)-2

调整背靠

背靠可多角度调节。

- 1- 背靠向上调节：拉住拉环，将背靠往上推(27)
- 2- 背靠向下调节：按住背靠调节按钮向下拉(28)

使用刹车

- 1- 踩下刹车踏板即可完成刹车(29)
- 2- 再次踩下刹车踏板即可完成释锁(30)
- ！ 手推车停止时，请刹车。轻轻推动手推车以确保刹车装置已启动。

前轮定向

- 1- 在碎石路面或不平路面推行时，建议锁定前轮，便能更轻松地操控手推车。
- 2- 前轮定向锁定见图(31)，前轮定向释锁见图(32)

收合手推车

- 1- 收合手推车前，请先确保两侧的钮扣已正确固定(33)
- 2- 收拢遮阳篷(34)
- 3- 推开第二道安全锁，然后按压单手按钮(35)
- 4- 轻轻往下推，车架自动收合并站立(36)-(38)
- 5- 车台收合后可使用肩背带，安装方式见图(39)-(41)
 - ！ 不使用肩背方式时，请将肩背带妥善保存。
- 6- 使用置物袋方便运输或储存(42)-(46)
 - ！ 放入置物袋前，需要将扶手移除(42)

使用配件

- ！ 因产品型号的不同，并非所有手推车均附以下配件。

使用雨篷

将雨篷套到座椅上(47)

- ！ 使用雨篷时，请随时注意并确认雨篷内有良好的通风。
- ！ 不使用雨篷时，请先确认雨篷已清洁并干燥，再收纳。
- ！ 请勿收合已罩上雨篷的手推车。
- ！ 天气炎热时，请勿将宝宝放在装有雨篷的手推车内。

维修与保养

可用湿布清洁车架和座布，请勿使用研磨剂或漂白剂。请勿使用润滑剂，因为它们会吸附灰尘和污垢。请勿将手推车储存在潮湿的地方。

请定期以水清洗轮子，并清除污垢。

为使手推车能长期使用，下雨天使用后，请用软质可吸水的布擦拭手推车。

请参考手推车上洗涤标的洗涤方式。

长期使用之后，在正常状况下，座布可能产生褪色、磨损或撕裂。

为确保安全，请使用Nuna原厂零配件。

请定期检查您的手推车功能是否正常与零件是否松弛磨损或脱落。一旦发生以上任何状况，请立即停止使用本手推车。

NUNA International B.V.

NUNA及所有相关徽标皆为商标。

NOTE

**IMPORTANT-
READ CAREFULLY
AND KEEP FOR
FUTURE REFERENCE**

Contents

Product Information	21
Product Registration	21
Warranty	21
Contact	21
Child Usage Requirements	22
Warnings	23
Parts List	27
Product Set Up	29
Product Use	31
Accessory	33
Rain Cover	33
Cleaning and Maintenance	34

Product Information

Model Number: _____

Manufactured Date: _____

Product Registration

Please fill in the above information. The model number and the manufactured date are located on a label on the stroller frame.

To register your product please visit:

www.nunababy.com

Click the “Register Gear” link on the homepage.

Warranty

We have purposely designed our high-quality products so that they can grow with both your child and your family. Because we stand by our product, our gear is covered by a custom warranty per product, starting from the day it was purchased. Please have the proof of purchase, model number and manufactured date available when you contact us.

For warranty information please visit:

www.nunababy.com

Click the “Warranty” link on the homepage.

Contact

For replacement parts, service, or additional warranty questions, please contact our customer service department.

info@nunababy.com

www.nunababy.com

In the United Kingdom:

infouk@nunababy.com

www.nunababy.com

NUNA International B.V.

Van der Valk Boumanweg 178 C

2352JD Leiderdorp

The Netherlands

Child Usage Requirements

This stroller is suitable for use with children who meet the following requirements:

Birth to 22 kg or 4 years whichever comes first.

When using the stroller frame with NUNA’s infant carrier, refer to the child usage requirements listed in those instruction manuals.

EN **!WARNING**

Failure to follow these warnings and instructions could result in serious injury or death.

Always use the restraint system.

Do not let the child play with this product.

Ensure that all the locking devices are engaged before use.

Never leave the child unattended.

This product is not suitable for running or skating.

To avoid injury ensure that the child is kept away when unfolding and folding this product.

Accessories which are not approved by the manufacturer shall not be used. Only replacement parts supplied or recommended by the manufacturer/distributor shall be used.

Adult assembly required.

ALWAYS set the parking brake when you stop.

Any damage caused by the use of accessories not supplied by Nuna will not be covered in terms of warranty.

Any load attached to the handle and/or on the back of the backrest and/or on the sides of the vehicle will affect the stability of the vehicle.

Be certain the stroller is fully erected and latched before allowing your child near the stroller.

DO NOT carry additional children, goods, accessories in or on the stroller except as permitted in this manual. They may cause the stroller to become unstable.

DO NOT leave the stroller exposed in the vicinity of a strong source of heat i.e. a radiator or open fire.

DO NOT place any item on the canopy.

DO NOT store the stroller in a damp place. Always allow the fabric to dry naturally away from direct heat.

DO NOT use storage basket as a child carrier.

DO NOT use the stroller if any parts are damaged or missing.

Keep small parts away from children as they pose a choking hazard.

Negotiate curbs and rough ground carefully. Repeated impact could cause damage to the stroller.

NEVER allow children to stand on the stroller.

NEVER carry more than one child at a time in the stroller.

NEVER use the stroller on stairs or escalators. You may suddenly lose control of the stroller or your child may fall out.

The harness must always be correctly fitted and adjusted. The harness is not a substitute for proper adult supervision.

The parking break shall be engaged when placing and removing children.

Overloading, incorrect folding, and the use of accessories e.g. child seats, bag hooks, rain covers, buggy boards, etc... other than those approved by Nuna may damage or make the stroller unsafe.

Rubber tires may leave black scuff marks on smooth surfaces such as parquet, laminate and linoleum.

STRANGULATION HAZARD Do not place items with a string around your child's neck, suspend strings from this product, or attach strings to toys.

To avoid any danger of suffocation, remove all plastic covers before using this item and destroy or keep away from babies and children!

To prevent a hazardous, unstable condition, do not place more than 4.5 kg in the storage basket.

USE the most reclined position for new born babies.

Use the stroller with a child weighing no more than 22 kg. It will cause damage to the stroller with an unfitted child.

NOTE

Parts List

Make sure all parts are available before assembly.
If any part is missing, please contact Nuna . No tools are required for assembly.

! **CHOKING HAZARD:** Remove and immediately discard protective end caps from each wheel and wheel hub axle.

- | | |
|-----------------------------------|------------------------------|
| 1 Stroller Frame | 15 Secondary Lock |
| 2 Armbar | 16 Handle |
| 3 Front Wheel (x2) | 17 One-Hand-Fold Button |
| 4 Rear Wheel (x2) | 18 Recline Adjustment Handle |
| 5 Canopy | 19 Storage Basket |
| 6 Armbar | 20 Rear Release Button |
| 7 Calf Support | 21 Rear Brake Lever |
| 8 Footrest | 22 Rear Wheel |
| 9 Front Swivel Lock | 23 Canopy Window |
| 10 Front Release Button | 24 Carrying strap |
| 11 Front Wheel | 25 Canopy |
| 12 Calf Support Adjustment Button | 26 Rain Cover |
| 13 Buckle | 27 Carry Bag Belt |
| 14 Shoulder Harness Pad | 28 Carry Bag |

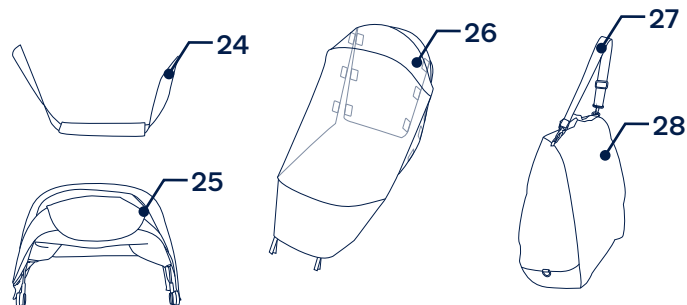
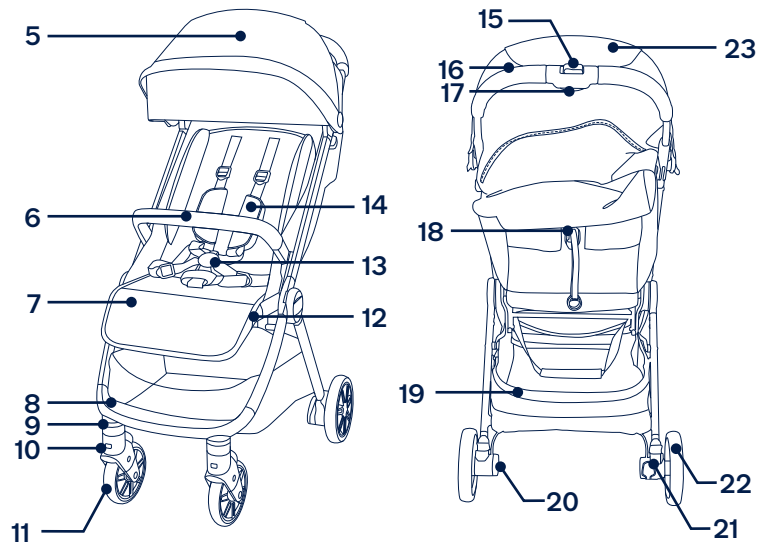
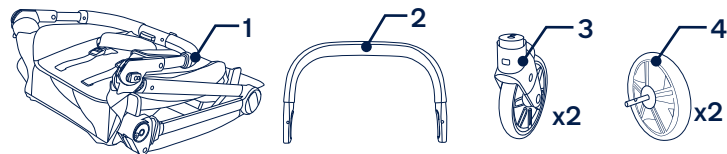

Product Set Up

Open Stroller

- 1 - Take the stroller frame out (1).
- 2 - Rotate the stroller handle up (2) , open the stroller frame (3)(4)
- 3 - A “click” sound means the stroller frame is open completely.
! Check that the stroller is completely latched open before continuing.

Basket

Hook the basket on the rear legs on the both sides. (5)

Rear Wheels

- 1 - Insert the rear wheel into the rear leg (6). A “click” sound means the rear wheel is assembled completely. Repeat on opposite side. (7)
! Check that the wheels are securely attached by pulling on them.
- 2 - To remove the rear wheel, press the release button (8)-1 and detach the rear wheel from the rear leg (8)-2.

Front Wheels

- 1 - Insert the front wheel into the front leg . A “click” sound means the wheel is assembled completely. (9) Check the wheel is securely attached by pulling out.

- 2 - To remove the front wheel, slide the release button out (10)-1 and then detach the front wheel from the front leg (10)-2.

Canopy

- 1 - Slide the canopy mounts onto the stroller (11). A “click” sound means the canopy is assembled completely. (12)
- 2 - Snap the buttons on the back panel of canopy to the backrest. (13)(14)

Armbar

- ! Always secure the child with the harness. The armbar is not a restraint device.
- 1 - Align the armbar ends with the armbar mounts, and insert until it clicks into place (15). A “click” sound means the armbar is assembled completely. (16)
 - 2 - To remove the armbar, press the armbar release buttons (17)-1, and lift the armbar up. (17)-2

Check Set Up

- Stroller frame is latched open
- Rear and front wheels securely attached
- Armbar securely attached

Product Use

Securing Your Child

! The parking brake **MUST** be engaged when the stroller is stopped and when placing and removing child.

! To avoid serious injury from falling or sliding out, always use the seat belt.

Make sure the harness is adjusted properly and your child is snugly secured. The space between the child and the shoulder harness should be about the thickness of one finger. **DO NOT** cross the shoulder belts. This will cause pressure on your child's neck.

- 1 - Press the button, the buckle will release automatically. **(18)**
- 2 - Match the waist belt buckle with the shoulder buckle, and align them with the center buckle, the buckle can lock automatically. **(19)**
- 3 - Fit the harness snugly to your child by sliding the adjustment straps to tighten **(20)-1**. Then pull the waist adjustment straps out **(20)-2**.

Shoulder Harness Position

The upper shoulder harness buckles can be moved up and down for added adjustment. **(21)**

Canopy

- 1 - To open the canopy, pull the canopy toward the front of the seat, and to close the canopy, push it back. **(22)**
- 2 - Unzip to open the canopy rear panel. **(23)**
- 3 - It is convenient to see the baby when rolling up the canopy rear panel. **(24)**

- 4 - For ventilation, flip up the top canopy window cover. **(25)**

Calf Support

The calf support has 2 positions.

- 1 - To raise the calf support, lift up.
- 2 - To lower the calf support, press the adjustment button in the middle of the calf support **(26)-1**, and push down **(26)-2**.

Recline

There are most recline positions.

- 1 - To raise the recline, push up. **(27)**
 - 2 - To recline the backrest, squeeze the backrest adjustment handle and pull the backrest down **(28)**.
- ! Make sure the recline is adjusted properly for use.

Brake

- 1 - To lock the rear wheels, step down on the brake lever. **(29)**
 - 2 - To unlock the rear wheels, step down the brake lever again. **(30)**
- ! Always apply the brake when the stroller is stopped. Push the stroller slightly to ensure the brake is engaged.

Front Swivel Locks

- 1 - It is recommended to use the front swivel locks on uneven surfaces.
- 2 - Front wheel orientation locked as fig **(31)**, Front wheel orientation released as fig **(32)**.

Fold

- 1 - Please make sure that the buttons on the both sides fastened correctly before folding the stroller. **(33)**
- 2 - Fold the canopy. **(34)**
- 3 - Slide the secondary lock and then squeeze the folding button **(35)**.
- 4 - The frame can fold and stand automatically while push it down slightly. **(36)-(38)**
- 5 - Can use the carrying strap to carry the stroller after folding as figs **(39)-(41)**.
 - ! Please store it well if do not use it.
- 6 - Grab the carry bag, the stroller will follow you. **(42)-(46)**
 - ! Please detach the armband before put it into carry bag. **(42)**

Accessory

- ! Not all accessories are included on some models.

Rain Cover

To assemble the stroller rain cover, place it over the stroller seat. **(47)**

- ! Always check ventilation, especially in hot weather when the rain cover is on the product.
- ! Always check that the rain cover has been cleaned and dried before folding.
- ! **DO NOT** fold the stroller after assembling the rain cover.
- ! **DO NOT** place your child into the stroller assembled with rain cover during hot weather.

Cleaning and Maintenance

Clean the frame, plastic parts, and fabric with a damp cloth, but do not use abrasives or bleach. Do not use silicon lubricants as they will attract dirt and grime. Do not store your stroller in a damp place.

Clean the stroller wheels regularly with water and remove any dirt.

To ensure long-lasting use, wipe off this product with a soft, absorbent cloth after using it in rainy weather.

Refer to the care label attached to the fabric for washing and drying instructions.

It is normal for fabric to color from sunlight and to show wear and tear after a long period of use, even when used normally.

For reasons of safety, only use original Nuna parts.

Check regularly if everything functions properly. If any parts are torn, broken, or missing, stop using this product.

